

## PREVENTING ROUGH-TERRAIN FORKLIFT ACCIDENTS

The most serious forklift accidents are those involving overturns, run-overs and work platforms. By addressing the hazards associated with these types of accidents, these accidents can be avoided.

### Forklift Operator Self-Test (True/False):

1. I have received forklift operator training within the last three years.
2. I have read the Operator's Manual(s) for the forklift(s) I operate.
3. I know how to read load charts and understand the "stability triangle."
4. I never drive with the load elevated.
5. I know the safety rules for using personnel work platforms.

If you answered **False** to any of these questions, for your safety and the safety of others, please read this bulletin and follow its precautions – you may need more training.



For Forklift Safety Manuals in Spanish and in English, visit:  
<http://www.aem.org>

**What you don't know can hurt you.**

## PERSONNEL WORK PLATFORMS

Safe use saves lives.

Rough-terrain forklifts are intended primarily for use as material handlers, but if there is no other practical option available, and if **such use is approved by the forklift manufacturer**, then use of an approved work platform is allowed, in accordance with the applicable safety standard: ANSI/ITSDF B56.6 - 2005.



# WARNING

**TO AVOID INJURY:**

- Never move forklift with a personnel work platform in a raised position or with personnel on the platform.
- Operator and work platform personnel must follow work platform safety rules: B56.6, Section 5.15, "Elevating Personnel."
- Personnel work platforms must comply with: B56.6, Section 8.24 "Platforms for Elevating Personnel."

This Best Practices bulletin was developed through OSHA's Alliance Program as a product of the OSHA and AEM Alliance and is for informational purposes only. It does not necessarily reflect the official views of OSHA or the U.S. Department of labor. 3/08

Printed in U.S.A.

## PREVENTING ROUGH-TERRAIN FORKLIFT ACCIDENTS

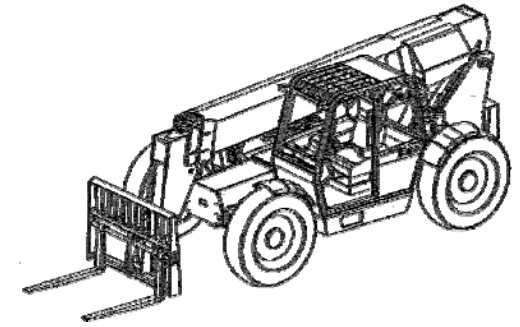

<http://osha.aem.org>

Best Practices Bulletin 3/08

# OPERATOR TRAINING

Safety begins with a safe operator.

Operator training reduces accidents, and it's required by law.

U.S. OSHA regulation, Title 29, section 1910, 178(I), requires employers in general industry and the construction, ship-yard and cargo-handling industries (excepting agricultural operations) to ensure that forklift operators are competent, as demonstrated by successfully completing a training course and being evaluated.

The training course must consist of a combination of formal instruction and practical training, including both forklift-related and workplace-related topics, and evaluation of the operator's performance in the workplace on the type of forklift that will be used.

All operator training and evaluation is to be conducted by persons who have the knowledge, training and experience to train and evaluate operators.

Refresher training is required at least every three years.

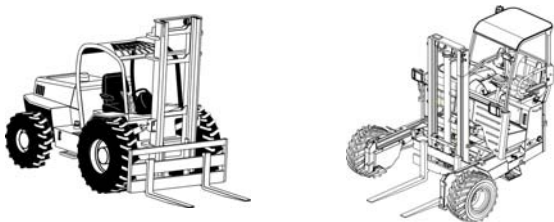

Know the rules – LIVE by them.

# HOW TO PREVENT OVERTURN AND RUNOVER ACCIDENTS





- Study load charts carefully. Operate only within stability limits of forklift.
- Look in the direction of travel and clear the path before moving the forklift.
- Carry load low. Avoid driving with load elevated, except for a short distance to pick or place a load.
- Move carefully on slopes. Operate only within specified grade limits.
- Before placing load: apply brakes, shift to Neutral, and level frame and engage stabilizers (if equipped).
- Retract boom/mast and lower carriage/forks before moving forklift.
- Before leaving operator's station, lower load to ground, shut off engine and apply parking brake.

## SAFETY RESOURCES

- ANSI/ITSDF B56.6 - 2005 – Safety Standard for Rough Terrain Forklift Trucks:  
<http://www.itsdf.org>
- OSHA publications:  
<http://www.osha.gov/pls/publications/publication.html>
- OSHA/AEM Alliance materials:  
<http://osha.aem.org>

# SAFETY IS NO ACCIDENT

Buckle up . . . for life.

 <b>WARNING</b>	
	
<ul style="list-style-type: none"><li>• Read Operator's Manual before operating forklift.</li><li>• Always fasten seat belt. If forklift overturns, DO NOT JUMP! Instead, hold on tight and lean away from the fall.</li><li>• Only start engine and operate controls from operator's seat.</li><li>• Do not allow minors or unqualified personnel to operate forklift.</li><li>• Do not position load by using frame leveling.</li><li>• Do not drive too close to ditches or excavations.</li></ul>	

Look out for others.